



Cofinox



Cofinox

Sheet metal industry

Cofinox

HEADQUARTER & SHIPPING
Ctra. de Molins a Sabadell, km 13
Nave 5 - Pol. Ind. Can Roses - 08191 Rubí (Barcelona)
Tel. 93 588 27 52 - Fax. 93 588 67 45
email: cofinox@cofinox.com



CUTTING SECTION
Parque Industrial Noguera, Nave 22 bis
Can Amat - 08630 Abrera (Barcelona)
Tel. 93 770 13 94 - Fax. 93 588 67 45

www.cofinox.es

High technology applied to metal
Stainless steel specialists

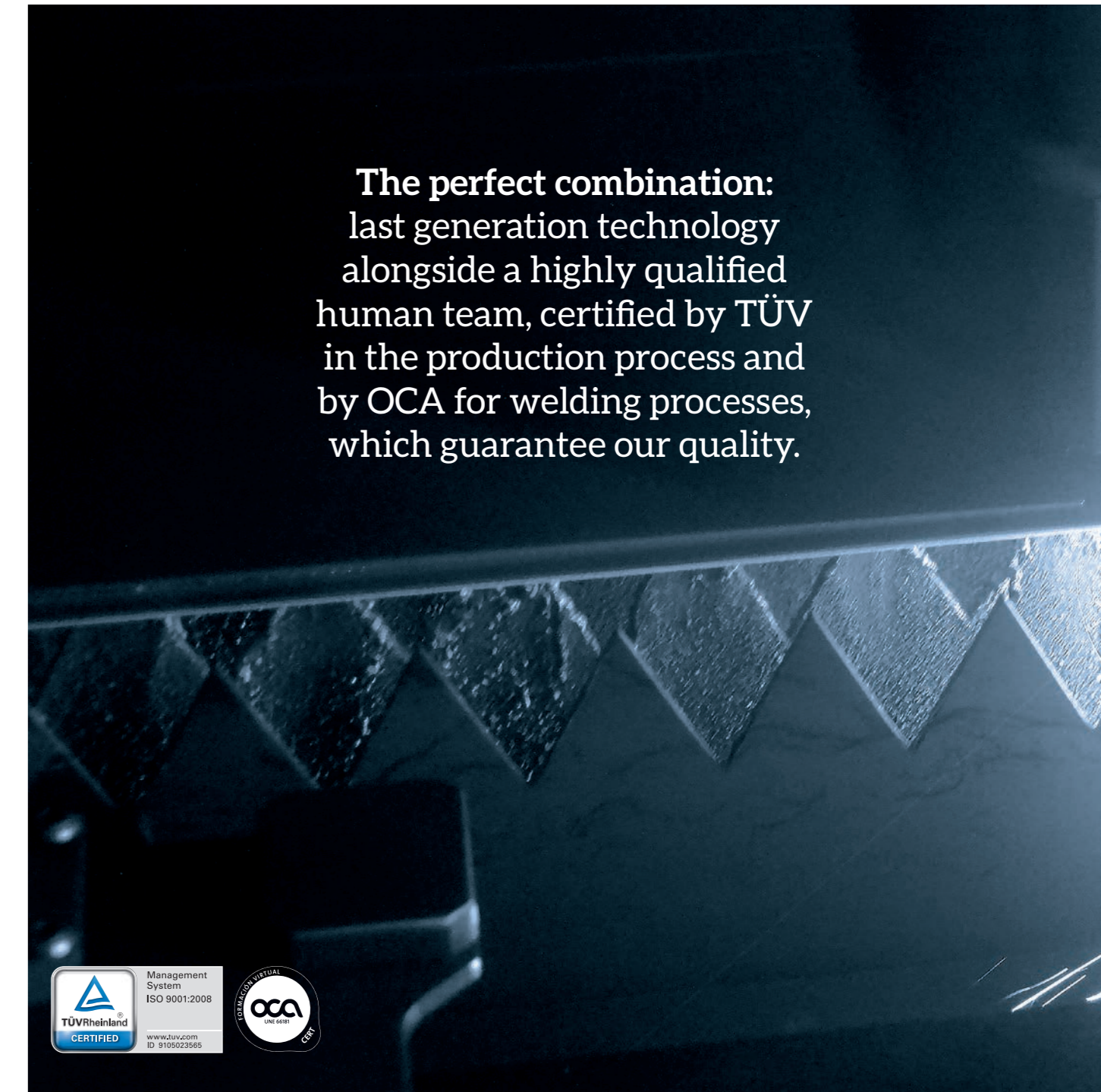
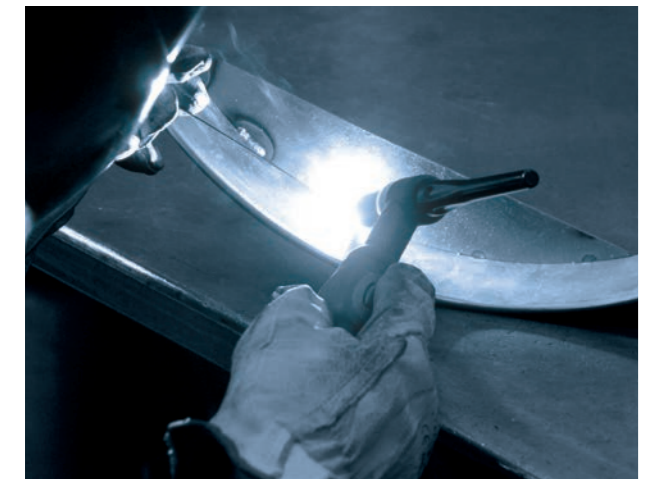

The perfect combination:
last generation technology
alongside a highly qualified
human team, certified by TÜV
in the production process and
by OCA for welding processes,
which guarantee our quality.



Our integral production process

From the design and development of the piece to the final finishing and / or even the assembly.



Our success lies in the experience and commitment of our highly qualified and consolidated human team and in the immediate access to the raw material for the optimization of delivery times.

Adapted to our customers requirements

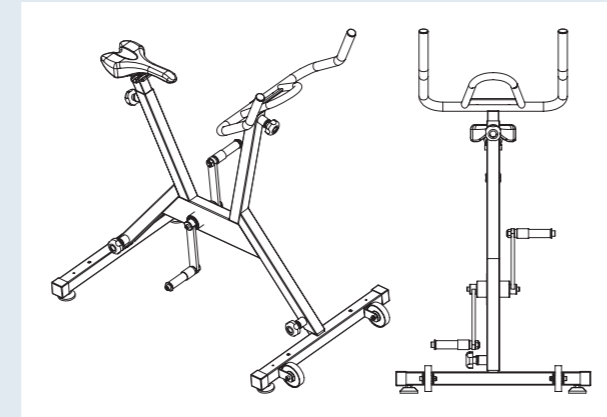

► Development of technical drawings.



► Renders previous to production.



► Making up and finishings of final product.

Quality commitment

Seriousness and commitment to our customers as the main objective.



COFINOX is certified by TÜV in the management of the processes with the standard EN UNE ISO 9001-2008. The experience and dedication of our human team as well as our customers' complicity have allowed us to offer a high quality service during the 25 years of life of our company.

With high-performance productive technology

During the last years we have incorporated into our production lines laser cutting machines, welding and bending robots of last generation that allow us to improve the product reliability as well as the productivity of our plants so that we offer a quicker response to all of our customers' projects.

Design and Development

- Concurrent engineering.
- Improvement on productivity.
- High-tech software tools.

Cutting

- Capacity of 40 meters / minute.
- Fiber (laser) and CO² Technologies.
- High-Speed Punch.

Bending

- Capacity of 9,600 bendings per day.
- Bending force of 125 Tn.
- Up to 3,000 mm of bending length.
- Closed boxes of 400 mm high.

Welding

- 96 linear meters of welding daily.
- TIG, MIG Technologies, Stainless steel, Steel, AL, CU.
- OCA homologations.

Quality

- ISO 9001-2008.
- OCA UNE-EN ISO 15614: 2005;
- UNE-EN ISO 15613: 2005.
- (Kaizen) continuous improvement.

Finishings

- Polished, Satin, Brilliant.
- Painted.
- Zinc plated, chromed, anodized, sandblasted...

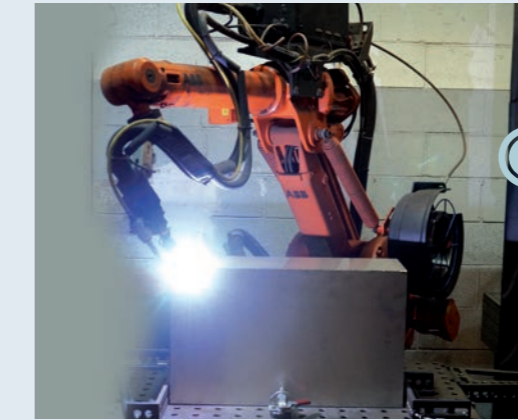

And presence in all industrial fields

Multiple products developed and manufactured in Cofinox are present in most international industrial fields. Automotive, Bathroom, Food and Beverage, Medical and pharmaceutical laboratories, Urban furniture, Meat industry, Electronics, Industrial weighing, Beauty and cosmetics.

